

Lead-Free* Brass Ball Valves - Solder

Two-Piece Body • Full Port • Blowout-Proof Stem • PTFE Seats

3/8"-2" 600 PSI Non-Shock Cold Working Pressure

2 1/2"-3" 400 PSI Non-Shock Cold Working Pressure



- NSF/ANSI 61-8 (INCLUDES ANNEX F & G)
- NSF/ANSI 372 • IAPMO IGC-157 • MSS SP-110

MATERIAL LIST

PART	SPECIFICATION
1. Body	Forged DZR Copper Alloy
2. End Cap	Forged DZR Copper Alloy
3. Ball Seat	PTFE
4. Ball	Stainless Steel or Chrome Plated Brass
5. Stem	Brass
6. O-Ring (Stem Seal)	Fluorocarbon (FKM)
7. Stem Packing	PTFE
8. Packing Nut	Brass
9. Lever Handle	Steel, Plated
10. Lock Washer	Stainless Steel
11. Handle Nut	Stainless Steel
12. Drain Cap*	Brass
13. Seat*	EPDM



S-FP-600A-LF



S-FP-600AD-LF
w/Drain

Note: *Parts 12 and 13 are applicable to valve with drain only.

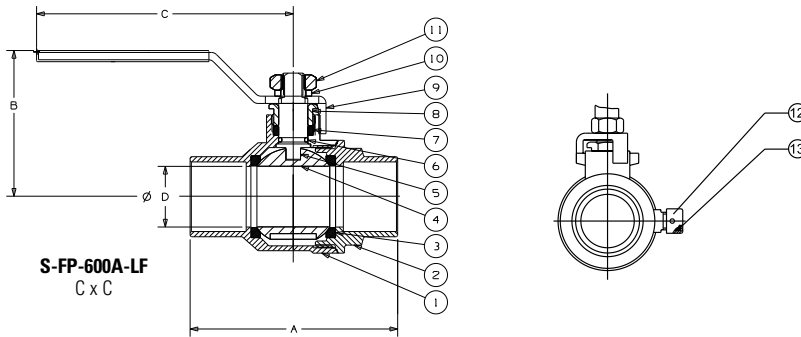

- Handle Options:**
- Lever
 - Extended lever

DIMENSIONS—WEIGHTS—QUANTITIES

Size	SFP600A-LF		SFP600AD-LF		A		B		C		Port D		Lbs.	Kg.	Ctn. Qty.
	In.	mm.	In.	mm.	In.	mm.	In.	mm.	In.	mm.	In.	mm.			
3/8	10	1.75	45	—	—	1.50	38	3.74	95	0.39	10	0.31	0.17	18	
1/2	15	1.97	50	2.13	54	1.77	45	3.74	95	0.59	15	0.41	0.18	18	
3/4	20	2.74	69	2.87	73	1.94	49	3.94	100	0.79	20	0.66	0.30	12	
1	25	3.35	85	3.50	89	2.52	64	4.33	110	0.98	25	1.20	0.51	6	
1 1/4	32	3.78	96	—	—	2.56	65	5.00	127	1.26	32	1.47	0.67	4	
1 1/2	40	4.41	112	—	—	3.04	77	6.18	157	1.57	40	2.42	1.08	2	
2	50	5.35	136	—	—	3.34	85	6.18	157	1.97	50	3.70	1.64	2	
2 1/2	65	6.24	158	—	—	4.76	121	9.45	240	2.56	65	7.49	2.88	3	
3	75	7.11	181	—	—	5.17	131	9.51	242	2.95	75	10.65	3.77	2	

*Weighted average lead content ≤ 0.25%